

Mobile Reel-To-Coil Machine

1 Hp 0-70 RPM 120 VAC Standard

Optional 2 Hp and 3 Hp Variable Speed Drive's Available.

0-70 or 0-35 RPM 230 VAC Single Phase.

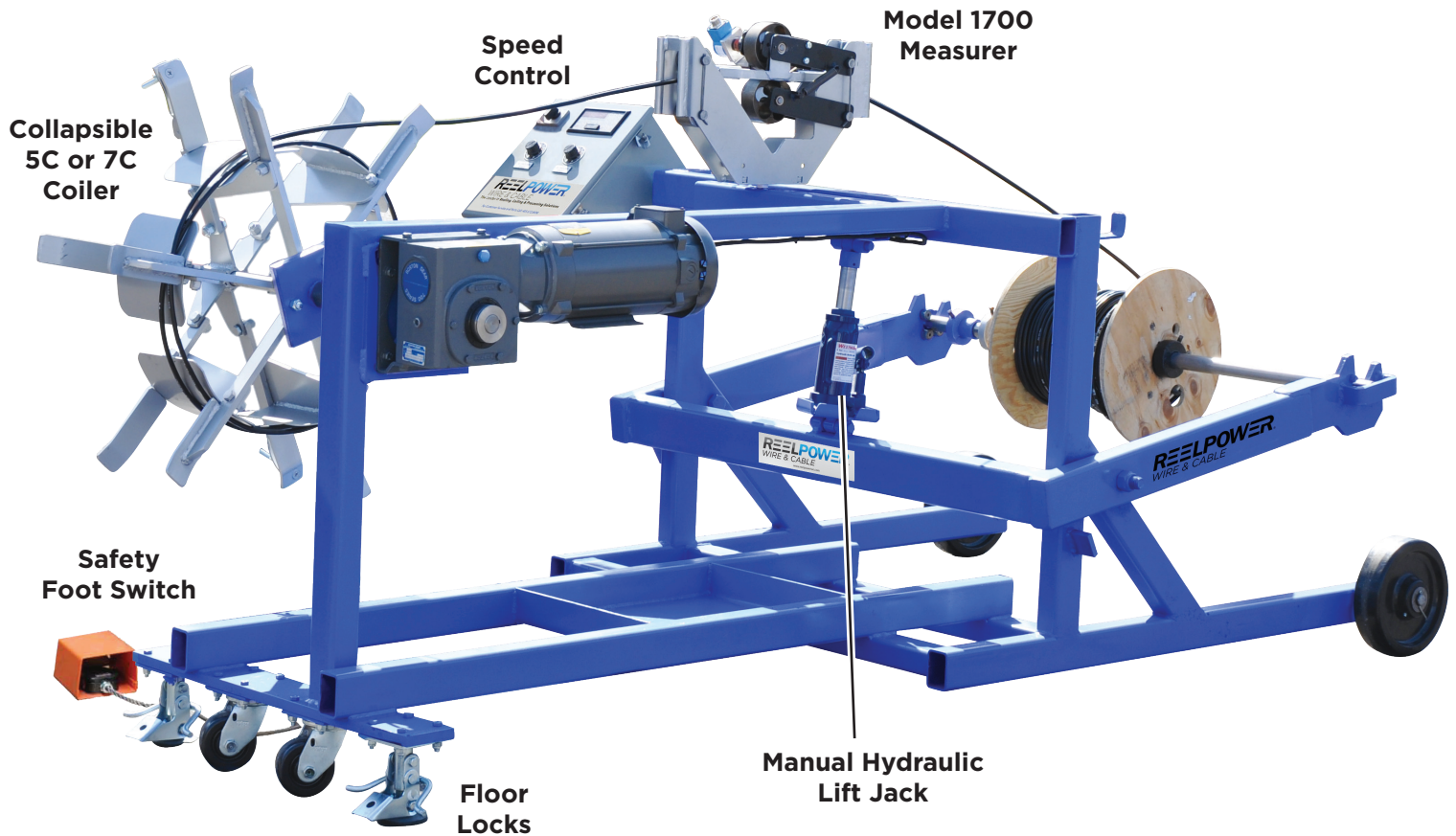

Mobile Reel-To-Coil Machine

Standard Specifications

- 1 HP SCR Variable Speed Drive, 0-70 RPM
- Pay-out capacity 20" to 48" dia. x 36" wide x 2,500 lbs.
- ROM 1700 Measurer - 1/8" to 2" dia. capacity
- 1 3/8" dia. Reel Shaft
- Bushings for 2", 2 1/2" and 3" arbor holes
- Heavy Duty Swivel Casters (rear)
- 10" Front Wheels
- Model 5C or 7C Collapsible Coilers
- Floor Locks
- Tool Tray
- Tape Storage Box

Options

- Electrolift
- Automatic Levelwind
- Shaft Attachment for Small Reels
- Coiler Guards
- Coiler/Shaft Plug-in Feature
- Manual Shaftless Feature
- Integral Cutters
- Pay-out Braking Systems
- Large Weight Capacities
- Predetermined Stop-To-Length Counters

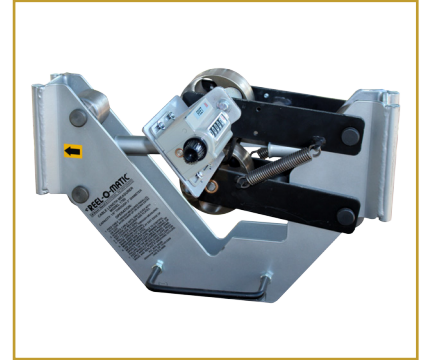

Model 1700 Measurer

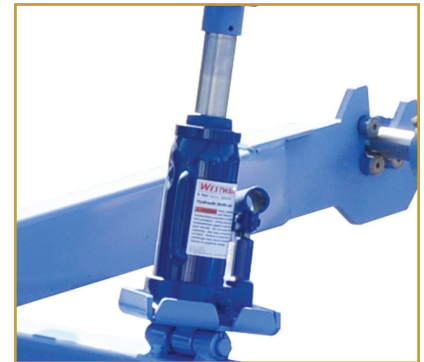

**Manual Hydraulic
Lift Jack**

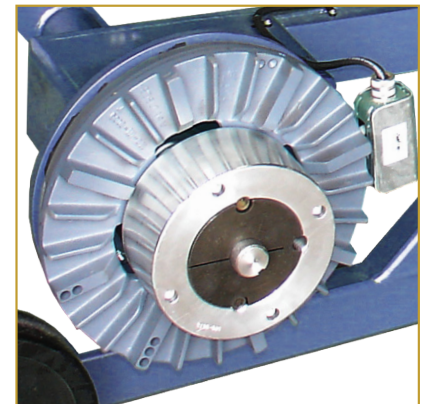

Pay-out Brake